

G

Dip Switch Settings

The default factory settings for the FZU-1342US01 Transmitter (TX) and Receiver (RX) units are 2D and 3D systems active. There are other setting options that can be set using the DIP switch on each unit. The DIP switch settings are different depending on the unit, TX, or RX. Please see below configuration.

DIP SWITCH SETTING:

TX UNIT	FUNCTION
Selector 1 (ON)	No function*
Selector 1 (OFF)	No function
Selector 2 (ON)	3D System Active*
Selector 2 (OFF)	3D System Non-active

DIP SWITCH SETTING:

RX UNIT	FUNCTION
Selector 1 (ON)	5 second delay on 3D activation*
Selector 1 (OFF)	5 second delay not active**
Selector 2 (ON)	3D System Active*
Selector 2 (OFF)	3D System Non-active

*Default Factory

**Does not comply to ASME if OFF

The 2D system is permanently active and cannot be deactivated.

The DIP switch is located inside each unit under the front lens filter. To access the switches to configure the FZU-1342US01, remove one or both lens filters from the front of the TX and RX edge. This is best achieved by prising free one top corner.

H

Connections



Conductor colours are:

Brown	24V	(18-30v)
Blue	Common	(Connected internally to ground)
Black	Signal output	(NPN normally closed)
Yellow	Data	(links RX toTX)

Door Controller / FPS Interface Unit

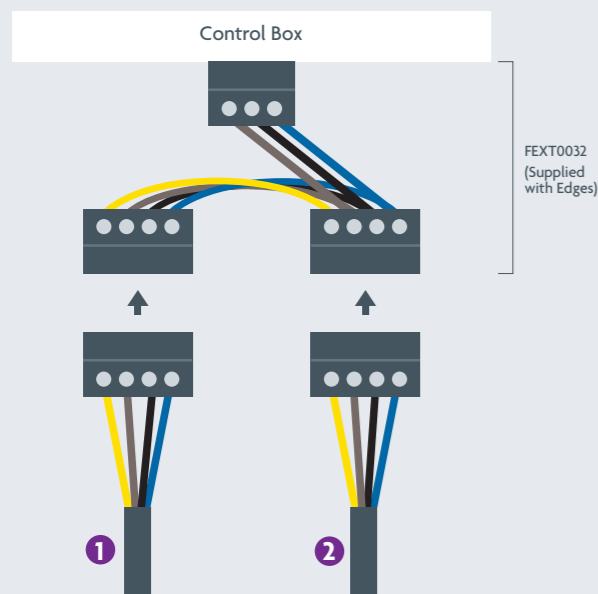

I

Testing/Commissioning



With both Transmitter (TX) and Receiver (RX) units installed, switch on the power.

With no object present in either the 2D beam path or within the entrance of the car, the system will go into a Non-Detection state. (No red LEDs illuminated on either TX or RX units.)

AT THIS POINT, IF EITHER TX OR RX RED LEDs ARE ILLUMINATED OR THE OUTPUT IS IN A DETECTION STATE, THEN PLEASE REFER TO 'TROUBLESHOOTING'.

FUNCTIONAL COMMISSIONING AGAINST CODE REQUIREMENTS:

Below points 1 & 2 require the doors to be parked in the fully open position. Point 3 is for manually moved doors. Point 4 requires the door to be placed back into full operation mode.

1. CONFIRM 2D BEAMS ARE FUNCTIONING

- Make sure no person or object is present in the entrance to the car.
- From within the car, to prevent possible 3D triggering, obstruct the 2D beam using hand.
- If the Edge detects the obstruction, the red LED on the RX edge will illuminate and output will be triggered.

2. CONFIRM 3D DETECTION IS FUNCTIONING

- Confirm that the system is in a Non-Detection State before test. No red LEDs should be illuminated on either TX or RX unit.
- Now approach the doors. When at between 20" - 9" detection should occur. This is seen by the red LED on the RX illuminating and detection output will be triggered.
- See below diagram for an illustration of the detection area from the floor.

NOTE: This red LED will stay illuminated for 5 seconds unless the 2D system has a detection occurrence event. If no detection is seen on the 2D system, then the 3D will then stop detecting.

If Point 1 & 2 are confirmed to be functioning correctly, the doors can be manually moved towards the closing point.

3. CONFIRM 3D DEACTIVATION IS FUNCTIONING

- With the doors approx. 18" apart the 3D system will be deactivated.
- If the test at Point 2 is completed the unit should not show detection.
- An alternative test to confirm 3D has been deactivated is as follows; after a time of 7 seconds the 2D will also stop detecting when an object is in the 2D beam path. (The system has now entered ECO mode state).

4. CONFIRM 3D SELF-TEST IS FUNCTIONING

- Place the door in full operational mode.
- Allow the door to close and then open a couple of times.
- Without causing detection to occur, observe the red LED on either of the TX or RX units.
- On the door opening cycle and once the door has reached the fully open position, both red LEDs will flash to indicate that a Self-Test has occurred. This will not cause a Detection Output to occur.
- With door in full operation mode, confirm 3D and 2D object detection occurs and door retraction is also observed.

DETECTION DISTANCE FOR 3D UNDER ASME:

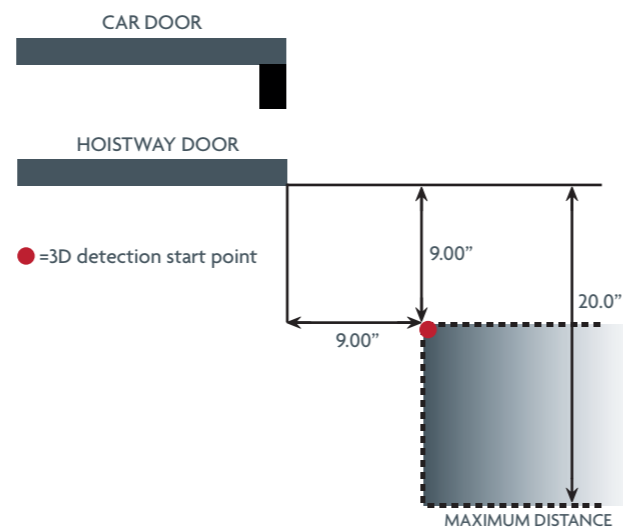

The diagram shows the TX unit only (left side of elevator) but the same distance criteria is applied to the RX unit (right side of elevator).

J

Troubleshooting



FIRST BASIC CHECKS TO CONFIRM:

A. DC POWER – A quick way to confirm is to verify that green LEDs are illuminated on both units. If not present on both TX and RX units then no DC power is present. Both must be illuminated.

B. DATA CONNECTION – The data connection (yellow wire) between the RX and TX edge must also be connected to each other for correct operation. If not connected the system will not work.

C. ORIENTATION – Although unlikely, it is possible to install the edges with the 3D beams facing into the car rather than out towards the landing. The correct location for each unit is: TX left, RX right of the car door when looking from the landing entrance into the car.

D. SIDE/SLAM MOUNTING – Please confirm that only the 4 provided mounting holes have been used for side mounting. If additional mounting points have been added, damage to the unit is probable and a replacement will need to be acquired.

E. DOOR/UNIT DISTANCE – Is the distance between the door/units greater than 70" (1800mm)? If they are, they are outside of the specified range of the Vision Plus product.

If the above five points are all confirmed to be correct and red LED illumination is still seen on either TX or RX units, then the following in the order shown should be used to resolve this issue.

NOTE: It is best practice to perform the following with the doors parked in the fully open position to prevent confusion. (Not in full operational mode)

RED LED ILLUMINATED:

This could be caused by 3 reasons, 3D in detection on either TX or RX or 2D is not functioning. To eliminate possible causes, a simple first test is to turn OFF the 3D sensors on both TX and RX units.

This is carried out using a DIP switch located towards the top inside of each unit under the lens filter. Turn OFF switch 2 on both TX and RX units, this will disable the 3D.

With both of these switches OFF, now check if the illuminated red LEDs have now turned OFF.

- If the red LEDs are OFF, the system should now work in 2D function only. If 2D function is confirmed to be working, then go to 3D detection system below.

- If the red LED on the RX unit is still illuminated, then the issue is with the 2D. Please again confirm points A-E at the start of this section.

3D DETECTION SYSTEM:

The system is now confirmed to be working in 2D mode with no lens fitted but there was on first start an issue when the 3D is enabled. The next step is to determine which 3D system is causing the issue - TX or RX. (This can be first performed with no lens fitted)

- Now in turn, switch back on the 3D, first the TX and then the RX. If switching back on the 3D on TX causes RED LED illumination, a Detection State, then turn the 3D on TX OFF and try turning on the RX 3D.

- If with either TX or RX 3D enabled, the red LED illuminates on the RX unit, Detection State, then please confirm again points A-E at the start of this section are correct.

- If enabling the 3D on either TX or RX does not cause the red LED to illuminate on the RX unit, check the Lens Filter for any contaminants (either in or outside the lens) such as; tape, paint etc. If present remove/clean, then with the 3D enabled on both TX and RX, refit the lens filter to each unit in turn to see if the issue is resolved.

- If with the lens filter fitted the system is now showing red LED illumination on the RX unit only, then switch OFF switch 2 on the RX unit to confirm the 3D is not the cause.

- If with RX switch 2 OFF, and the red LED is illuminated on the RX unit, then 2D is the cause, please confirm points A-E at the start of this section.

You should now have a functioning unit that can now be tested against code requirements. Refer to the 'Testing/Commissioning' section of this document.

For further information please visit www.formula-systems.com

LEADING EDGE TECHNOLOGY



LEAF0325 ISS 07

INSTALLATION GUIDE

Vision Plus - FZU-1342-US01



A

Parts List

Ensure you have identified all of the components

	Quantity
1 Vision Plus Transmitter (Edge)	1
2 Vision Plus Receiver (Edge)	1
3 Cable Retainer	2
4 Washer M4 Plain	10
5 Washer M4 External Toothed Locked	10
6 'P' Clip Size 7.9 Natural White	10
7 Screws M4 x 20mm Pan Head taptite	18
8 Screw 4.8 x 13 Hex Washer Self Drill	4
9 Drill 3.6mm HSS S/S Jobber	1
10 Cable Extension	1
11 Spacer Block	1
12 Clear adhesive labels	14
13 Clamp Plate	5
14 Screws M4 x 20mm Socket Head taptite	19
15 3mm Hexagon Key	1

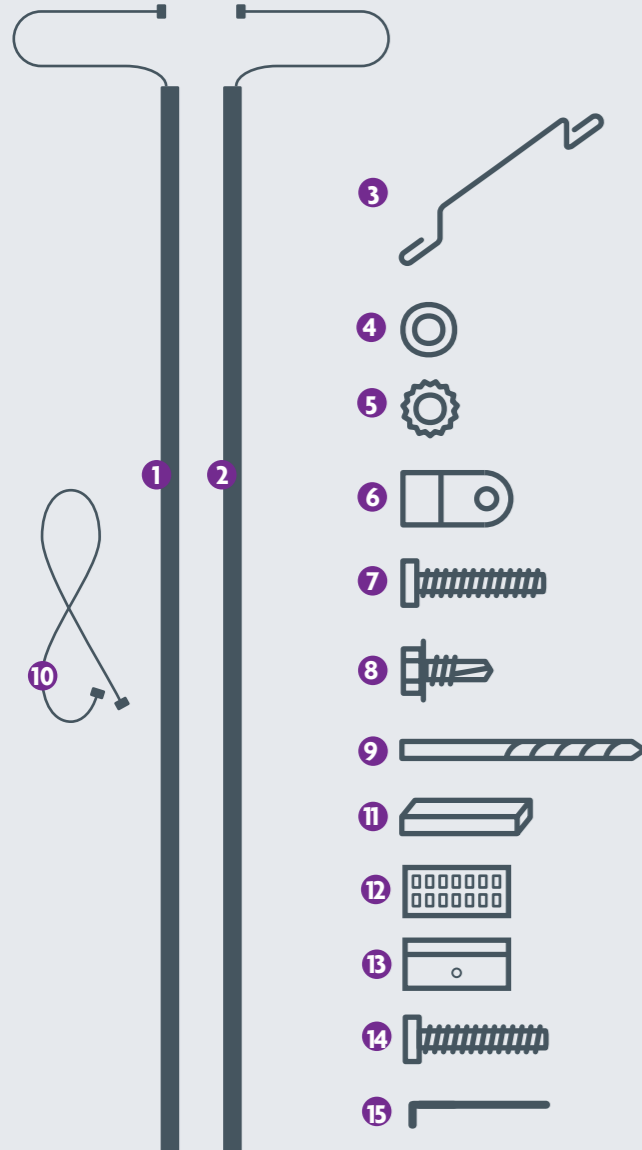

CO

(Centre Opening)

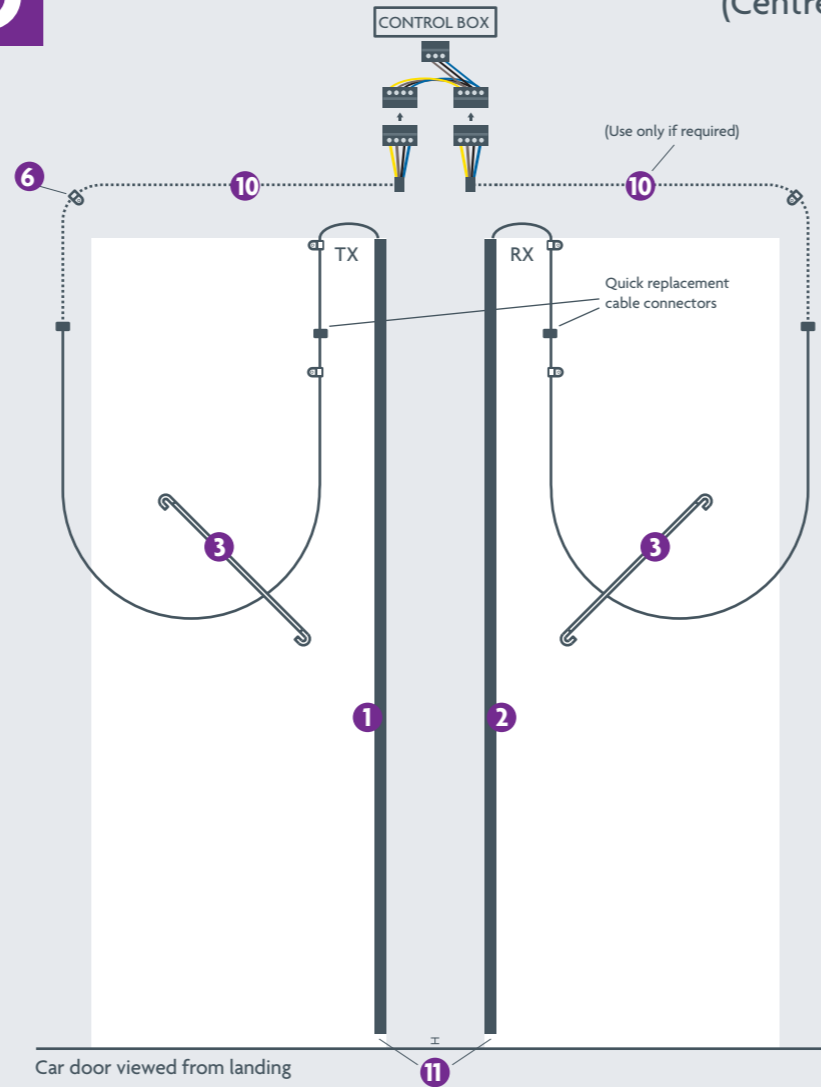

SO

(Side Opening)

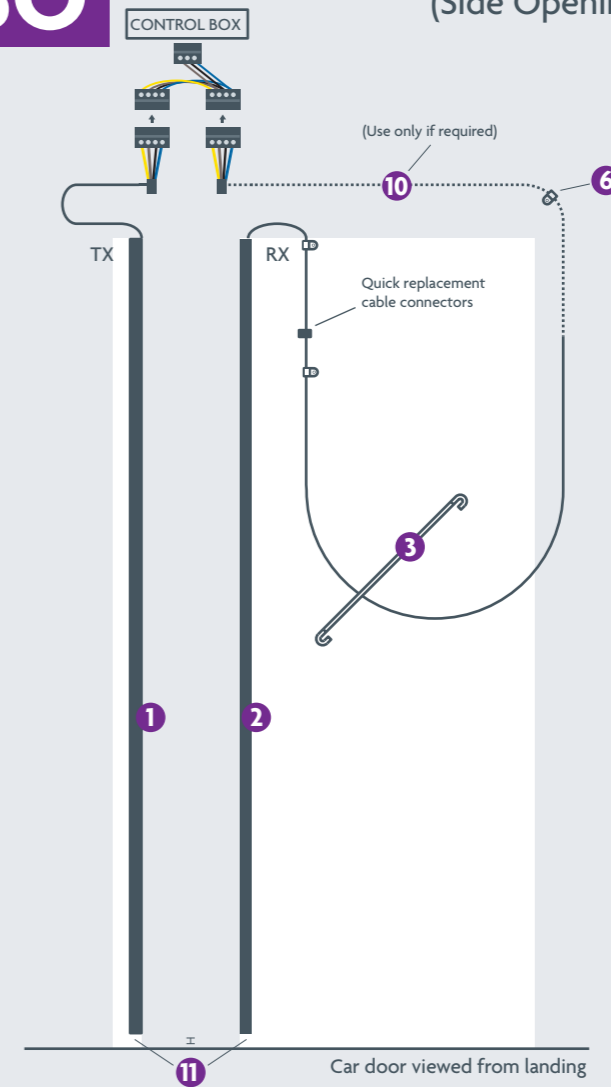

SO (Slam)

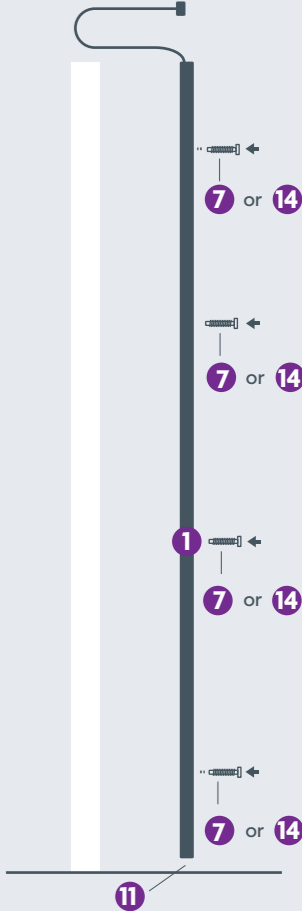

B

Installation

CO Place spacer **11** on floor. Rest edge on spacer
SO Position edge against door leaving a gap of 3mm - 6mm (0.1" - 0.25") between front face of edge and leading edge of door
 Secure edge in place using screws **7** in following sequence: top, bottom, middle, remainder after drilling pilot holes with drill **9**
 Repeat above for second edge.

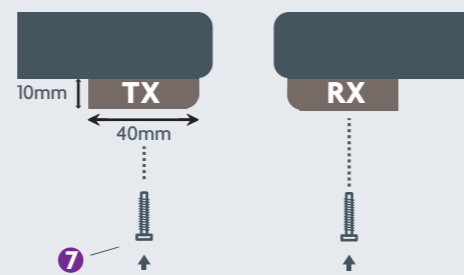

NOTE: Screw **14** can be used instead of screw **7**
NOTE: Unlike a simple 2D system, the 3D edge is handed. The TX and RX must be installed with the TX on the left side when facing into the car and the lens profiles curved toward the landing to facilitate good transmission angles for the 3D features.

B

Installation

SO Secure the Edge to the slam post with the Clamp Plates **13** and M4 Socket Screw **14** using the 3mm hexagon key **15** provided.

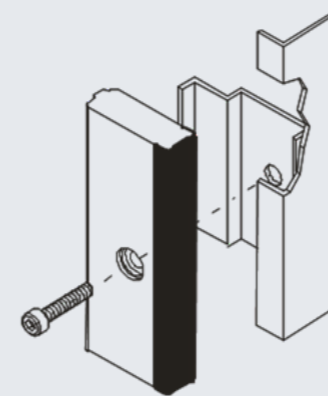

C

Installation

CO On mounting completion affix Clear Adhesive Labels **12**
SO These are to be placed over each mount hole to prevent contaminants from entering the product.
 This forms part of the IP54 acceptance.

D

Cable Routing

CO Route the cables and attach 'P' Clips **6** either side of connectors to hold in place.
SO Use screw **7** and washers **4** and **5** after drilling pilot holes with drill **9**

E

Cable Routing

CO Fix cable retainer(s) **5** to doors using screws **8**
SO

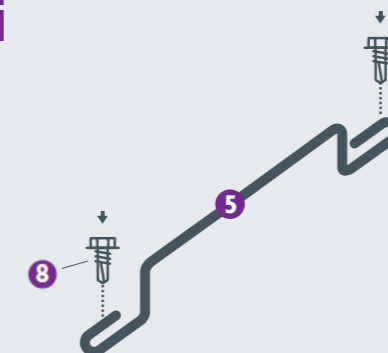

F

Routine Maintenance

CO The system will be maintained in optimum working condition if the plastic lens filter on the leading edge of the Vision Plus units are periodically cleaned.
SO Extreme build-up of dirt and dust can cause beam obstruction and subsequent false triggering.